

ROOFLAM®



NF 537
Actuated safety devices (DAS)
Control devices (DC)



EN 12101-2
EN 1873 + A1: 2016

Évolution Pneumatique



VERSION



Filling

ORIGIN' RANGE:

- Opal PCA 10



Upstand

- 310 mm high GRP base with a skewed insulated opening



Control

- Pneumatic opening/closing
- Built-in mechanism

The ROOFLAM® ÉVOLUTION PNEUMATIQUE is an NSHEV intended primarily for smoke and heat exhaust applications. It is suitable for use on dry roofs on all types of buildings (including public facilities, work premises and industrial buildings).

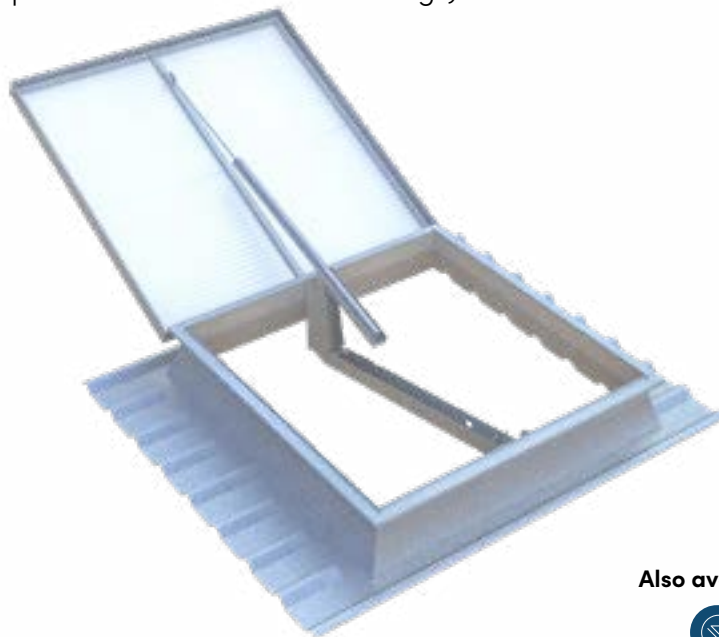

Also available:



OPTIONS



Types of filling

- Opal PCA 16 IR
- Grey PCA 16
- Transparent PCA 16
- PCA 10+ Lumira*
- Insulated aluminium cover
- Triple dome



Upstand

- Lacquered interior and exterior (standard RAL colours)



Control

- Limit switch
- Thermo-fuse (93°C as standard)



Other information

- 6 mm round bar or 16x16 mm 1200 joule square tube grid, galvanised or lacquered in standard RAL
- Anti-sawing burglar-resistant grid (16x16 mm + R6 tube assembly), galvanised or lacquered in standard RAL
- Variable thickness of insulation on underside



RAL colours on exterior surfaces

- Standard colour
- RAL colours at no extra cost**

RAL 9010*

RAL 5008

RAL 7015

RAL 7022

RAL 8012

** Interior colour: RAL 9010 only

** Contact us if you require a different colour

FUNCTIONAL OPTIONS



Electric or pneumatic ventilation kit

Available versions



Dimensions

Roof opening dimensions CA x CB (cm)	Roof joist dimensions* (cm)	Height H* (cm)		Light surface (m ²)	Product weight*** (kg)	
		PCA	DD		PCA	DD
100 x 100	Use the base search engine on the website www.skydome.eu	37	56	1.00	83	89
120 x 120		37	59	1.44	96	106
140 x 140		37	62	1.96	109	122
150 x 150		37	64	2.25	114	130
160 x 160		37	65	2.56	121	140
100 x 150		37	56	1.50	92	102
100 x 200		39	59	2.00	116	130
120 x 200		39	59	2.40	125	141
140 x 200		39	62	2.80	135	-
120 x 250		39	59	3.00	135	-

Contact us for other dimensions.

* Stated base dimensions have a tolerance of +/- 5 mm.

** For a base height of 310 mm.

*** Stated weight is for the product on a dry roof.

Filling performance

Other filling and filling options: see "Filling" data sheet.

Type of filling		Thermal transmittance factor Ug (W/m ² .K)	LT D65 ⁽²⁾	SF or g ⁽²⁾	Reaction to fire	R _w (dB) ⁽³⁾
		U _{hor} ⁽¹⁾				
PCA	Opal 4-wall PCA 16	1.9	45%	46%	B-s1-d0	R _w =21 dB
	Transparent PCA 16 with Lumira™ aerogel	1.5	67%	67%	B-s1-d0	R _w =21 dB
	Opal multi-wall PCA 20	1.6	54 %	47%	B-s2-d0	R _w =21 dB
	Transparent multi-wall PCA 32	1.3	33%	49%	B-s2-d0	ND
	Transparent PCA 32 with Lumira™ aerogel	0.97	43%	45%	ND	ND
Cover	40 mm aluminium cover	0.85	0%	ND	ND	ND
Dome	Opal PMMA triple dome Opal PMMA upper dome + transparent PMMA interior dome + transparent PMMA lower dome	2.76	ND	ND	ND	ND
	Opal PMMA triple dome Opal solid PC upper dome + transparent solid PC interior dome + transparent solid PC lower dome	2.76	ND	ND	ND	ND
Acoustik' Light	Acoustik' Light Transparent PCA 10 & transparent PCA 6	2.1	ND	ND	ND	ND

⁽¹⁾As per §2.31 of the Th-Bat regulations.

⁽²⁾Light transmittance LT D65 and total solar transmittance SF (TST or g) as per EN 410.

⁽³⁾Filling insulated against airborne noise R_w, pink noise R_A (environment, airport and industrial activities) and road noise R_{A,Tr}, laboratory-measured according to NF EN ISO 140.

Technical diagrams

THERMIK' range

ROOFLAM ÉVOLUTION PNEUMATIQUE PCA

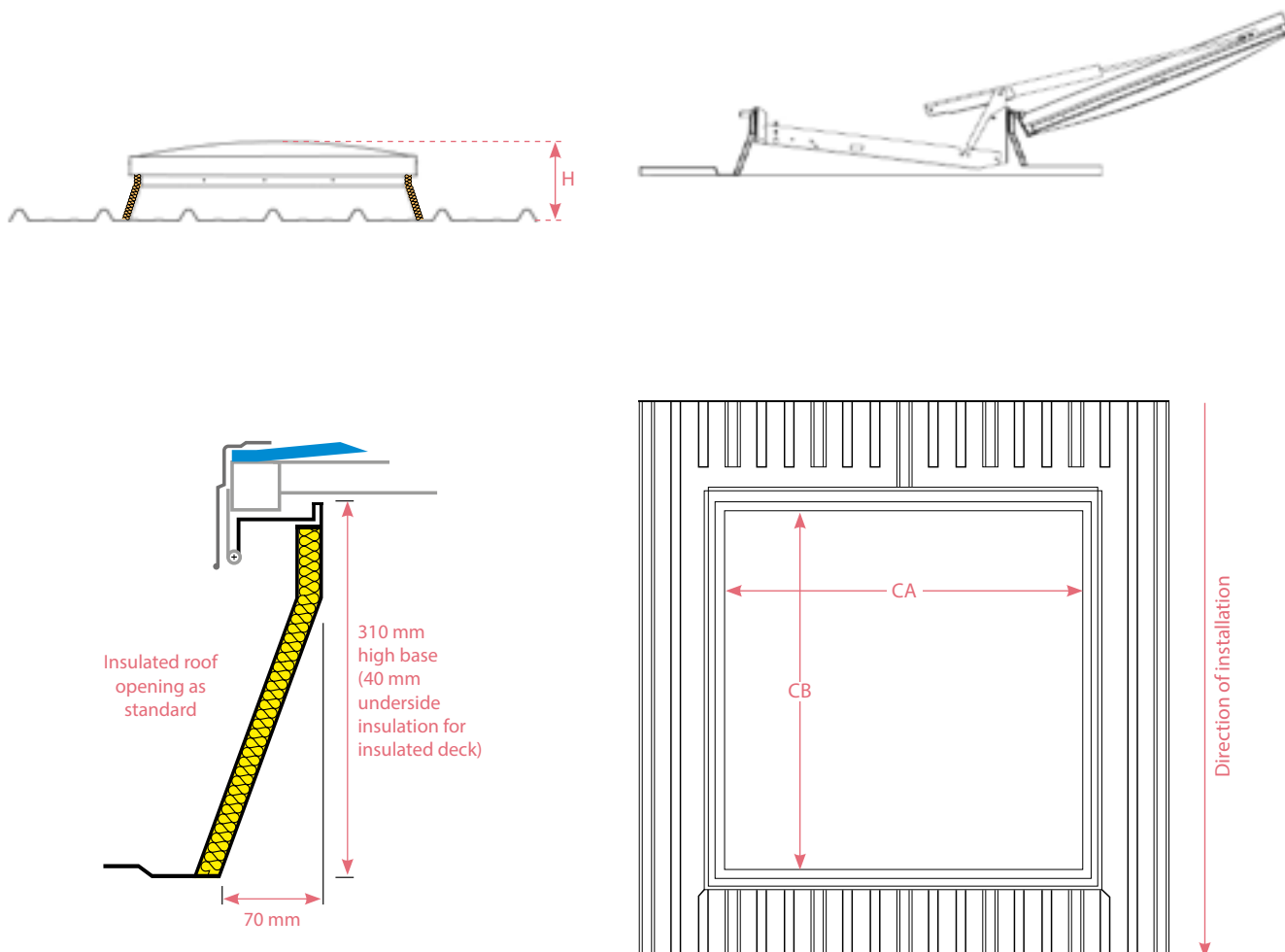

PERFORMANCE

Exhaust ventilator opening: type B (open + close)

Reliability: Re 1000 + 10000 (with ventilation kit)

Low ambient temperature: T(0°C)

Resistance to heat: B₃₀₀

Thermo-fuse set temperature: 93°C to 183°C thermo-fuse, set to 93°C (as standard)

Resistance to wind load: WL1500

Opening under load: SL250 or SL500 depending on filling and dimensions

Also available in Storm grade WL3000 for dimensions < 140 x 140 cm. Contact us for details.

COMPLIANCE & INSTALLATION

CE certified NSHEV compliant with **NF EN 12101-2 (product certification No. 0333 CPR 219017)**.

• The product must be fastened and sealed in accordance with the requirements defined in the applicable DTUs in series 40.35 (NF P 34-205-1).

Maximum permitted inclination with the hinge parallel to the roof slope:

- If geometric area (Av) → 25° or 46.65 %
- If geometric area (Av) → 20° or 36.45 %

In both cases, the hinges are positioned on the right, as seen when looking towards the ridge.

Maximum permitted inclination with the hinge perpendicular to the roof slope: 25° or 46.65%.

- If geometric area (Av) → 20° or 36.45 %

In this case, the hinges must be positioned nearest the bottom of the slope.

Only the security bar option provides guaranteed 1200 joule protection.

DoP available at www.skydome.eu

Maximum permissible snow loads SL (Pa) and operating pressure (bar)

Roof opening (cm)	Jack volume (Litre)	Closing pressure (bar)	Opening pressure (bar)							
			PCA 16 / PCA 16+		PCA 32 / PCA 32+ / 40 mm cover		PCA 32 & dome		PCA 32+ & dome / Triple dome / Acoustik' Light	
			SL250	SL500	SL250	SL500	SL250	SL500	SL250	SL500
100 x 100	1.7	10	10	15	10	15	10	15	10	15
120 x 120	1.9		10	15	10	15	10	15	10	15
140 x 140	2.0		13	22	14	23	14	23	23	
150 x 150	2.0		16	27	17	28	17	28	28	
160 x 160	2.7		16	26	17	27	17	27	27	
100 x 150	1.7		10	15	10	15	15		15	
100 x 200	1.7		11	18	11	20	20		20	
120 x 200	1.9		14	24						
140 x 200	2.0		17	30						
120 x 250	1.9		17	28						

Centred crosspiece

Aeraulic performance

Dimensions (cm)	Av (m ²)	Aa (m ²)	
		SD	AD
100 x 100	1.30	0.70	0.87
120 x 120	1.80	0.97	1.20
140 x 140	2.37	1.27	1.60
150 x 150	2.69	1.43	1.82
160 x 160	3.03	1.61	2.05
100 x 150	1.87	1.01	1.25
100 x 200	2.44	1.32	1.64
120 x 200	2.87	1.45	1.95
140 x 200	3.03	1.68	2.24
120 x 250	3.54	1.71	2.41

*Valid for 30 mm insulated bases only.

**Effective light surface calculated with white lacquered upstand and PCA 16 and U_{gc} according to NF EN 1873.

***Air permeability tests carried out at the CSTC test centre as per NF EN 1873 protocols (with reference to the standards NF EN 12152 and NF EN 12153).

Trade name

Trade name	Filling	Upstand insulation
ROOFLAM ÉVOLUTION PNEUMATIQUE	THERMIK' 16	16 mm PCA (Opal PCA)
	THERMIK' 16+	16 mm PCA with LUMIRA (Transparent PCA)
	THERMIK' 32	32 mm PCA (Transparent PCA)
	THERMIK' 20	20 mm PCA (Opal PCA)
	THERMIK' 20+	20+ mm PCA with LUMIRA (Transparent PCA)
	THERMIK' 32+	16 mm PCA + 16 mm PCA with LUMIRA (Transparent PCA)
	THERMIK' 3xD	Triple dome (Opal upper dome + transparent interior dome + transparent lower dome)
	THERMIK' 40 OPAQUE	40 mm aluminium cover
	THERMIK' ACOUSTIK' LIGHT	10 mm PCA + 6 mm solid PC
		Upstand height: 310 mm Insulation: • on vertical part of upstand

$U_{RC} : 2 \text{ W/m}^2 \cdot \text{K}$

ENHANCED THERMAL INSULATION:

- ✓ **Wide range of filling options** with different thermal insulation, light transmittance and solar factor performance
- ✓ **Compliant with applicable DTU specifications**
- ✓ $U_{RC} = 2 \text{ W/m}^2 \cdot \text{K}^*$

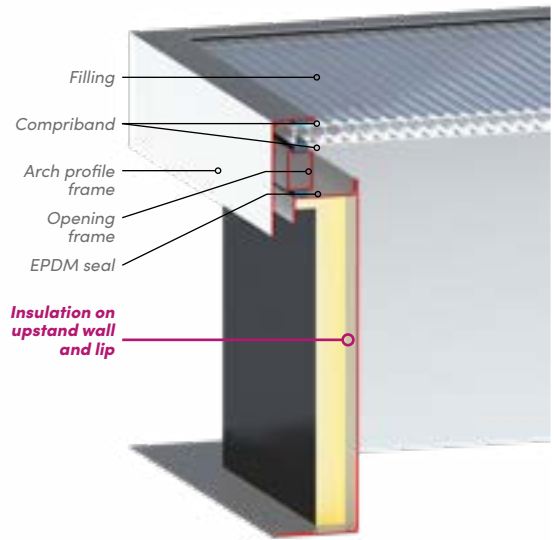

Thermal performance: U_{RC} ($\text{W/m}^2 \cdot \text{K}$) and A_{RC} (m^2)

ROOFLAM® ÉVOLUTION PNEUMATIQUE									
Dimensions (cm)	Upstand height: 310 mm								
	U_{RC}						Opaque 40 mm aluminium cover	Triple dome	A_{RC}
	Acoustik' Light	PCA 16	PCA 16+	PCA 20	PCA 32**	PCA 32+			
100 x 100	2.7	2.6	2.5	2.5	2.4	2.3	2.2	3.4	2.6
120 x 120	2.7	2.6	2.4	2.5	2.3	2.2	2.1	3.3	3.4
140 x 140	2.6	2.5	2.4	2.4	2.2	2.1	2	3.3	4.2
150 x 150	2.6	2.5	2.3	2.4	2.2	2.1	2	3.3	4.6
160 x 160	2.6	2.5	2.3	2.3	2.2	2.1	1.9	3.3	5.1
70 x 100	2.8	2.7	2.6	2.6	2.5	2.4	2.3	3.4	3.5
100 x 150	2.7	2.6	2.4	2.5	2.3	2.2	2.1	3.3	4.4
100 x 200	2.6	2.5	2.3	2.4	2.2	2.1	2	3.3	4.9
120 x 200	2.6	2.5	2.3	2.4	2.2	2.1	2	3.3	5.5
120 x 250	2.6	2.5	2.3	2.3	2.1	2	1.9	3.3	5.9
140 x 200	2.6	2.5	2.3	2.3	2.1	2	1.9	3.3	-

* For a 120 x 250 cm unit with a 310 mm high upstand and PCA 32+ filling.
 ** Adding a dome has no effect on the unit's thermal conductivity U_{RC} .





SKYDÔME

Entre Deux Villes
02270 Sons-Et-Ronchères, France
Tel: +33 (0)3 23 21 79 90
Email: info@skydome.eu
www.skydome.eu

For the product range in other countries, please contact your local representative or visit www.skydome.eu.

SKYDÔME reserves the right to modify product specifications without notice. The information and technical details contained in this documentation are provided in good faith and apply to the uses described. The recommendations for use must be checked to ensure they are appropriate and comply with the actual requirements, the specifications and all applicable legislation and regulations.

For other applications and conditions of use, please contact our technical team. Their advice must be sought concerning uses of our products that are not described specifically herein.

Click this link to check that you are seeing the most up-to-date and accurate information about our products:
https://www.skydome.eu/fr/produit/20_rooflam-evolution-pneumatique.html

For **WATERPROOFED ROOFS OR EXISTING UPSTANDS**

ROOFLAM®

Évolution Pneumatique



NF 537
Actuated safety devices (DAS)
Control devices (DC)



EN 12101-2
EN 1873 + A1: 2016



VERSION



Filling

ORIGIN' RANGE:

- Opal PCA 10



Upstand

- 310 mm high GRP base with a skewed insulated opening



Control

- Pneumatic opening/closing
- Built-in mechanism

The ROOFLAM® ÉVOLUTION PNEUMATIQUE is an NSHEV intended primarily for smoke and heat exhaust applications. It is suitable for use on dry roofs on all types of buildings (including public facilities, work premises and industrial buildings).

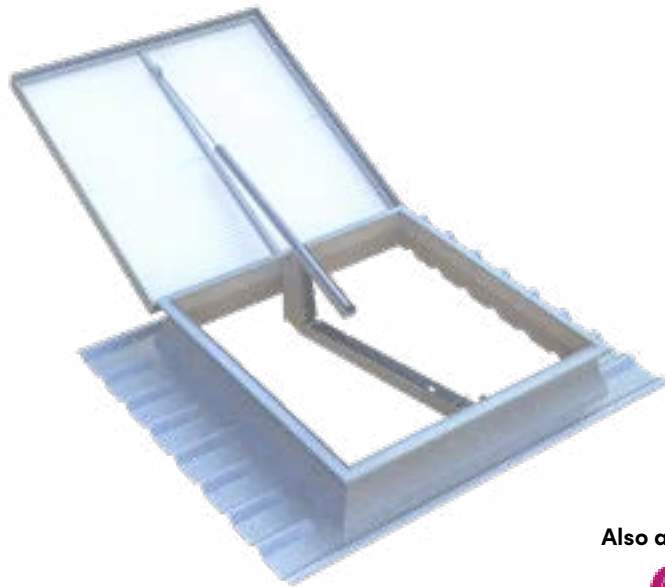

Also available:



OPTIONS



Types of filling

- Opal PCA 10 IR
- Grey PCA 10
- Transparent PCA 10
- PCA 10+ Lumira*
- Insulated aluminium cover
- PMMA double dome
- Triple dome



Upstand

- Lacquered interior and exterior (standard RAL colours)



Control

- Limit switch
- Thermo-fuse (93°C as standard)



Other information

- 6 mm round bar or 16x16 mm 1200 joule square tube grid, galvanised or lacquered in standard RAL
- Anti-sawing burglar-resistant grid (16x16 mm + R6 tube assembly), galvanised or lacquered in standard RAL
- Variable thickness of insulation on underside



RAL colours on exterior surfaces

- Standard colour
- RAL colours at no extra cost**

RAL 9010*

RAL 5008

RAL 7015

RAL 7022

RAL 8012

** Interior colour: RAL 9010 only

** Contact us if you require a different colour

FUNCTIONAL OPTIONS



Electric or pneumatic ventilation kit

Available versions



www.skydome.eu

SKYDÔME®

Dimensions

Roof opening dimensions CA x CB (cm)	Roof joist dimensions* (cm)	Height H* (cm)		Light surface (m ²)	Product weight*** (kg)	
		PCA	DD		PCA	DD
100 x 100	Use the base search engine on the website www.skydome.eu	37	56	1.00	83	89
120 x 120		37	59	1.44	96	106
140 x 140		37	62	1.96	109	122
150 x 150		37	64	2.25	114	130
160 x 160		37	65	2.56	121	140
100 x 150		37	56	1.50	92	102
100 x 200		39	59	2.00	116	130
120 x 200		39	59	2.40	125	141
140 x 200		39	62	2.80	135	-
120 x 250		39	59	3.00	135	-

Contact us for other dimensions.

* Stated base dimensions have a tolerance of +/- 5 mm.

** For a base height of 310 mm.

*** Stated weight is for the product on a dry roof.

Filling performance

Other filling and filling options: see "Filling" data sheet.

Type of filling	Thermal transmittance factor Ug (W/ m ² .K)	LT D65 ⁽²⁾	SF or g ⁽²⁾	Reaction to fire	R _w (dB) ⁽³⁾	
	U _{hor} ⁽¹⁾					
PCA	Opal 4-wall PCA 10	2.9	61%	61%	B-s1-d0	R _w =19 dB
	Transparent PCA 10 with Lumira™ aerogel	ND	ND	ND	ND	ND
Cover	40 mm aluminium cover	0.85	0%	ND	ND	ND
Domes	Opal PMMA double dome Opal PMMA upper dome + transparent PMMA interior Dome + transparent PMMA lower dome	2.89	84%	ND	ND	ND
Acoustik' Light	Acoustik' Light Transparent PCA 10 & transparent PCA 6	2.1	ND	ND	ND	ND

⁽¹⁾As per §2.31 of the Th-Bat regulations.

⁽²⁾Light transmittance LT D65 and total solar transmittance SF (TST or g) as per EN 410.

⁽³⁾Filling insulated against airborne noise R_w, pink noise R_p (environment, airport and industrial activities) and road noise R_{RA}, laboratory-measured according to NF EN ISO 140.

Technical diagrams

ORIGIN' range

ROOFLAM ÉVOLUTION PNEUMATIQUE PCA

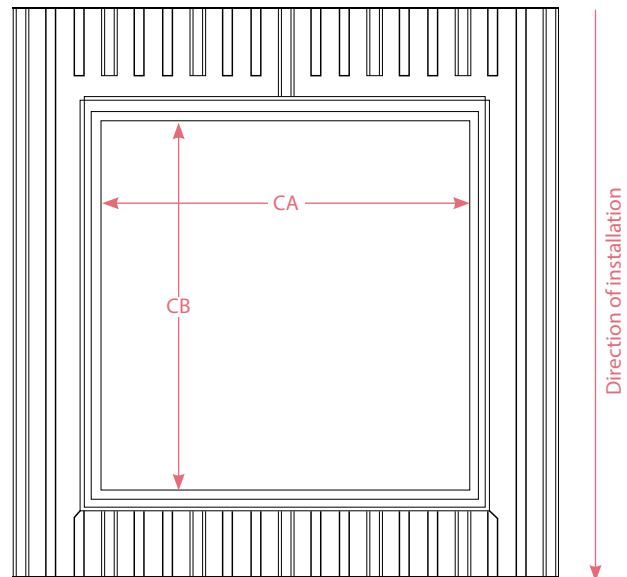
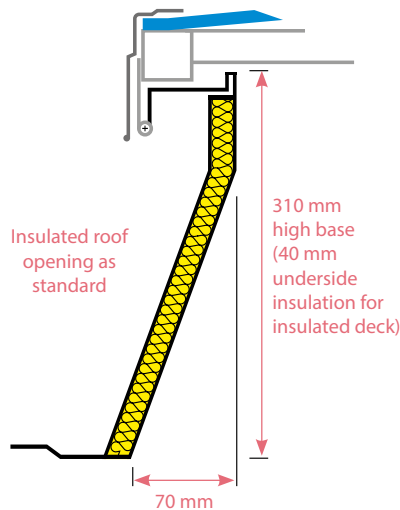
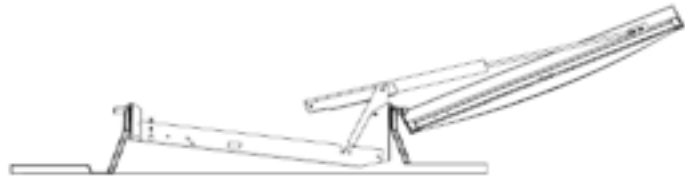
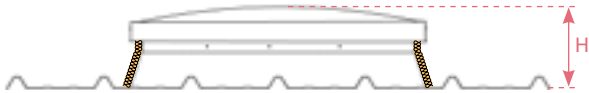

PERFORMANCE

Exhaust ventilator opening: type B (open + close)

Reliability: Re 1000 + 10000 (with ventilation kit)

Low ambient temperature: T(0°C)

Resistance to heat: B₃₀₀

Thermo-fuse set temperature: 93°C to 183°C thermo-fuse, set to 93°C (as standard)

Resistance to wind load: WL1500

Opening under load: SL250 or SL500 depending on filling and dimensions

Also available in Storm grade WL3000 for dimensions < 140 x 140 cm. Contact us for details.

COMPLIANCE & INSTALLATION

CE certified NSHEV compliant with **NF EN 12101-2 (product certification No. 0333 CPR 219017)**.

• The product must be fastened and sealed in accordance with the requirements defined in the applicable DTUs in series 40.35 (NF P 34-205-1).

Maximum permitted inclination with the hinge parallel to the roof slope:

- If geometric area (Av) → 25° or 46.65 %

- If geometric area (Av) → 20° or 36.45 %

In both cases, the hinges are positioned on the right, as seen when looking towards the ridge.

Maximum permitted inclination with the hinge perpendicular to the roof slope: 25° or 46.65%.

- If geometric area (Av) → 20° or 36.45 %

In this case, the hinges must be positioned nearest the bottom of the slope.

Only the security bar option provides guaranteed 1200 joule protection.

DoP available at www.skydome.eu

Maximum permissible snow loads SL (Pa) and operating pressure (bar)

Dimensions (cm)	Jack volume (Litre)	10 et 16 mm PCA		Double dome		Aluminium cover	
		SL250	SL500	SL250	SL500	SL250	SL500
100 x 100	1.7	10	15	10	15	10	15
120 x 120	1.9	10	15	10	15	10	15
140 x 140	2.0	13	22	14	23	14	23
150 x 150	2.0	17	27	17	28	17	28
160 x 160	2.7	16	26	17	27	17	27
100 x 150	1.7	10	15	10	15	10	15
100 x 200	1.7	11	18	11	20	11	20
120 x 200	1.9	14	24	•	•	•	•
140 x 200	1.9	17	28	•	•	•	•
120 x 250	2.0	17	30	•	•	•	•

•: Unavailable
Closing pressure for all dimensions: 13 bar

Aeraulic performance

Dimensions (cm)	Av (m ²)	Aa (m ²)	
		SD	AD
100 x 100	1.30	0.70	0.87
120 x 120	1.80	0.97	1.20
140 x 140	2.37	1.27	1.60
150 x 150	2.69	1.43	1.82
160 x 160	3.03	1.61	2.05
100 x 150	1.87	1.01	1.25
100 x 200	2.44	1.32	1.64
120 x 200	2.87	1.45	1.95
140 x 200	3.03	1.68	2.24
120 x 250	3.54	1.71	2.41

*Valid for 30 mm insulated bases only.

**Effective light surface calculated with white lacquered upstand and PCA 16 and U_e according to NF EN 1873.

***Air permeability tests carried out at the CSTC test centre as per NF EN 1873 protocols (with reference to the standards NF EN 12152 and NF EN 12153).





SKYDÔME

Entre Deux Villes
02270 Sons-Et-Ronchères, France
Tel: +33 (0)3 23 21 79 90
Email: info@skydome.eu
www.skydome.eu

For the product range in other countries, please contact your local representative or visit www.skydome.eu.

SKYDÔME reserves the right to modify product specifications without notice. The information and technical details contained in this documentation are provided in good faith and apply to the uses described. The recommendations for use must be checked to ensure they are appropriate and comply with the actual requirements, the specifications and all applicable legislation and regulations.

For other applications and conditions of use, please contact our technical team. Their advice must be sought concerning uses of our products that are not described specifically herein.

Click this link to check that you are seeing the most up-to-date and accurate information about our products:
https://www.skydome.eu/fr/produit/20_rooflam-evolution-pneumatique.html